

---

# Table of Content

<b>Chapter 1. Introduction .....</b>	<b>3</b>
1.1 Product Overview .....	3
1.2 Specification .....	4
1.3 Component Placement .....	7
1.4 Block Diagram .....	8
<b>Chapter 2. Hardware Setup .....</b>	<b>9</b>
2.1 Jumper and Connector Location .....	9
2.2 CPU and DRAM Setting .....	12
2.3 CMOS Setting .....	12
2.4 Watchdog Timer Setting .....	13
2.5 Embedded Solid State Disk .....	14
2.6 Power and Fan Connector .....	15
2.7 VGA Interface .....	16
2.8 Ethernet Interface .....	20
2.9 Audio Interface .....	21
2.10 Switch and Indicator .....	22
<b>Chapter 3. BIOS Setup .....</b>	<b>23</b>
<b>Chapter 4. Driver Installation .....</b>	<b>25</b>
<b>Appendix. A I/O Port Pin Assignment .....</b>	<b>27</b>
A.1 IDE Port .....	27
A.2 Floppy Port .....	28
A.3 Parallel Port .....	29
A.4 Serial Port .....	30
A.5 USB Port .....	31
A.6 IrDA Port .....	31
A.7 VGA Port .....	32
A.8 LAN Port .....	32
A.9 AT Keyboard Port .....	33
A.10 PS/2 Keyboard and Mouse Port .....	33

---

<b>Appendix B.</b>	<b>Flash the BIOS</b> .....	<b>35</b>
B.1	BIOS Auto Flash Tool .....	35
B.2	Flash Method .....	35
<b>Appendix C.</b>	<b>System Resource</b> .....	<b>37</b>
C.1	I/O Port Address Map .....	37
C.2	Memory Address Map .....	38
C.3	IRQ and DMA Resource .....	39

---

# Chapter 1. Introduction

## 1.1 Product Overview

The FS-977PRO SBC (Single Board Computer) is an all-in-one industrial full-size PICMG (PCI/ISA)-bus CPU card based on Intel Socket 478 Pentium 4 architecture. With Intel Brookdale-GV chipset, Intel 845GV GMCH and ICH4, FS-977PRO offers the value computing solution including Intel NetBurst micro-architecture, 533/400 MHz of FSB, 2 GB DDR SDRAM, Intel Extreme Graphics with 266 MHz VGA core, 256-bit 3D engine, Intel Dynamic Video Memory up to 64 MBytes, LVDS interface, TV-out, one Intel PRO/100+ LAN and one Intel PRO/1000+ LAN, Hi-Speed USB 2.0 and M-systems DiskOnChip solid state flash disk interfaces.

Based on the Intel's long term supply chipset in the EIA (Embedded Intel Architecture) division's product roadmap, FS-977PRO should be the ideal solution for the industrial applied computing platform with high computing capacity, cost effect and long life cycle. With Intel's latest technology, the FS-977PRO should be the leading edge of computing capacity for the advanced industrial computing platform with the features as below.

### **Intel Hyper-Threading Technology**

The FS-977PRO supports Intel Hyper-Threading Technology to offer the better computing capacity for the industrial applied computing application. Based on Intel's latest technology, "the Intel Pentium 4 Processor with Hyper-Threading technology allows software programs to "see" two processors and work more efficiently. Improves performance and system responsiveness in today's multitasking environments by enabling the processor to execute instruction threads in parallel."

### **Powerful Computing Capacity**

With Intel's latest CPU technology, FS-977PRO supports Intel Socket 478 Pentium 4 CPU up to 3.06 GHz at 533 MHz of FSB and low cost Intel Socket 478 Celeron CPU up to 2.4 GHz at 400 MHz of FSB. The FS-977PRO also provides two GBytes of DDR200/266/333 of system memory capacity.

**Hi-Speed USB 2.0 Interface:** Intel ICH4 built-in Hi-Speed USB 2.0 controller offers the Hi-Speed USB 2.0 interface with up to 480 Mbps of data transfer bandwidth with the USB bootable setting in the BIOS.

---

## 1.2 Specification

### General Specification

<b>Form Factor</b>	Full-size PICMG-bus CPU Card / Slot PC PICMG version 1.0 (Rev. 2.0), PCI version 2.0 compliant
<b>CPU</b>	Intel Socket 478 Pentium 4 / Celeron CPU at 400/533 MHz FSB (100/133MHz x 4) Intel 0.13-/0.18-micron Northwood / Willamette CPU <b>Support Intel Hyper-Threading Technology</b>
<b>Memory</b>	Two 184-pin DIMM sockets support up to 2 GBytes DDR200/266/333 SDRAM.  (No ECC/register DIMM support)
<b>Chipset</b>	Intel 82845GV GMCH and 82801DB ICH4
<b>BIOS</b>	Phoenix-Award 2Mb PnP flash BIOS
<b>Green Function</b>	Power saving mode supported in BIOS with DOZE, STANDBY and SUSPEND modes. ACPI version 1.0 and APM version 1.2 compliant
<b>Watchdog Timer</b>	Generates NMI or system reset programmable watchdog timer with 1 to 255 sec./min. of time out value
<b>Real Time Clock</b>	Intel ICH4 built-in RTC with onboard lithium battery
<b>Enhanced IDE</b>	PCI enhanced IDE interface supports dual ports up to 4 ATAPI devices with UltraATA/100 supported Jumper selectable Vcc power output on IDE2 for power cable free DOM (DiskOnModule) flash disk
<b>ISA High Drive</b>	ISA 64mA high Drive capacity with TI 245 buffer on both of ISA address and data bus

### Solid State Disk Interface

<b>Flash Type</b>	M-systems DiskOnChip 2000, DiskOnChip Millennium, IDE Pro and DiskOnModule (DOM) solid state flash disk
<b>Package</b>	32-pin DIP JEDEC (DiskOnChip) 40-pin IDE port (DOC IDE Pro, DiskOnModule)
<b>Capacity</b>	1 GB of DiskOnChip and 512 MB of DiskOnModule

---

## Multi-I/O Port

---

<b>Chipset</b>	Intel 82801DB ICH4 and Winbond W83627HF-AW LPC super-I/O controller
<b>Serial Port</b>	Two RS-232 serial ports. Both with 16C550 compatible UART and 16 bytes FIFO.
<b>USB 2.0 Port</b>	Four Hi-Speed USB 2.0 ports with Intel ICH4 Support 480 Mbps of data transfer rate
<b>Parallel Port</b>	One bi-direction parallel port with SPP/ECP/EPP mode
<b>Floppy Port</b>	One floppy port supports up to two FDD
<b>IrDA Port</b>	One IrDA compliant Infrared interface supports SIR
<b>K/B &amp; Mouse</b>	PS/2 keyboard and mouse ports, AT keyboard port

---

## VGA Display Interface

---

<b>Chipset</b>	Intel 845GV GMCH built-in Intel Extreme Graphics with 266 MHz VGA core
<b>Video Memory</b>	Intel Dynamic Video Memory with auto detect video memory up to 64 MBytes shared with system memory
<b>Display Type</b>	CRT and LCD monitor LVDS Color LCD
<b>LCD Interface Connector</b>	24-bit single/dual channel LVDS interface External DB15 female connector on bracket for CRT Dual Internal 20-pin header for LVDS interface Internal 16-pin header for analog VGA display

---

## TV-out Interface

---

<b>Chipset</b>	Intel 845GV GMCH built-in Intel Extreme Graphics with Chronitel CH7017A-T TV-out encoder
<b>TV Mode</b>	Support both of NTSC and PAL mode
<b>Connector</b>	Internal 8-pin header for TV-out interface

---

---

---

## Ethernet Interface

---

<b>Chipset</b>	One Intel PRO/100+ LAN interface and one Intel PRO/1000+ LAN interface Primary LAN (LAN1): Intel ICH4 with Intel 82562ET Phy Secondary LAN (LAN2): PCI Intel 82540EM
<b>Type</b>	LAN1:10Base-T / 100Base-TX, auto-switching Fast Ethernet Full duplex, IEEE802.3U compliant LAN2: 10Base-T / 100Base-TX/1000Base-T auto-switching Fast Ethernet Full duplex, IEEE802.3, 802.3u, 802.3ab compliant

---

## Audio Interface

---

<b>Chipset</b>	Intel ICH4 built-in AC97 3D audio controller with codec
<b>Interface</b>	Line-in, line-out, CD-in, Mic-in

---

## Power and Environment

---

<b>Power Req.</b>	+5V, +12V, -12V DC input from PICMG backplane Additional +12V on 4-pin connector for Pentium 4 PSU
<b>ATX Function</b>	3-pin ATX interface with 5V standby and power-on
<b>Dimension</b>	338 (L) x 122 (H) mm, standard PICMG form factor
<b>Temperature</b>	Operating within 0 ~ 60°C (32 ~ 140°F) Storage within -20 ~ 85°C (-4 ~ 185°F)

---

### EMI

---

## Ordering Code

---

**FS-977PROVXL** Full-size PICMG Socket 478 Pentium 4 DDR CPU Card with 533/400 MHz FSB, Intel Extreme Graphics, Intel PRO/100+ LAN , **LVDS interface**, TV-out, Audio, Hi-Speed USB 2.0, DOC Socket and ISA 64mA High Drive Capacity

**FS-977PROVXL2** Same as FS-977PROVL but with **Intel PRO/100+ LAN and Intel PRO/1000+ LAN**

---

---

## 1.3 Component Placement

System Memory  
2 x 184-pin DIMM Sockets  
2 GB DDR200/266/333

Intel 845GV GMCH  
Built-in Intel  
Extreme Graphics

ITE8888 ISE Bridge  
Winbond 83627HF-AW  
LPC Super-I/O

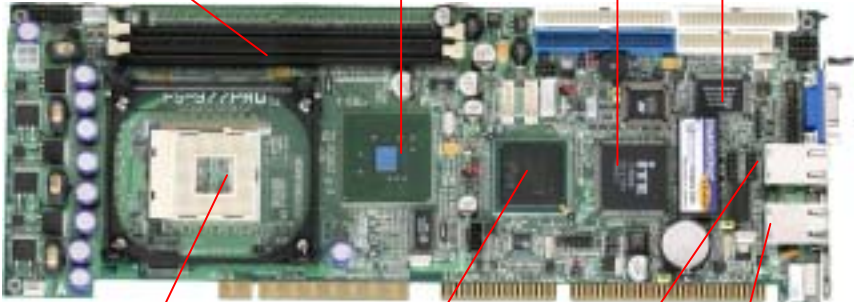

mPGA478 CPU Socket  
Intel Pentium 4 / Celeron  
533/400 MHz FSB

Intel 82801DB ICH4  
Built-in Hi-Speed  
USB 2.0 Interface

Intel PRO/100+ LAN  
Intel ICH4 with 82562ET

Intel PRO/1000+ LAN  
with 82540EM

# 1.4 Block Diagram

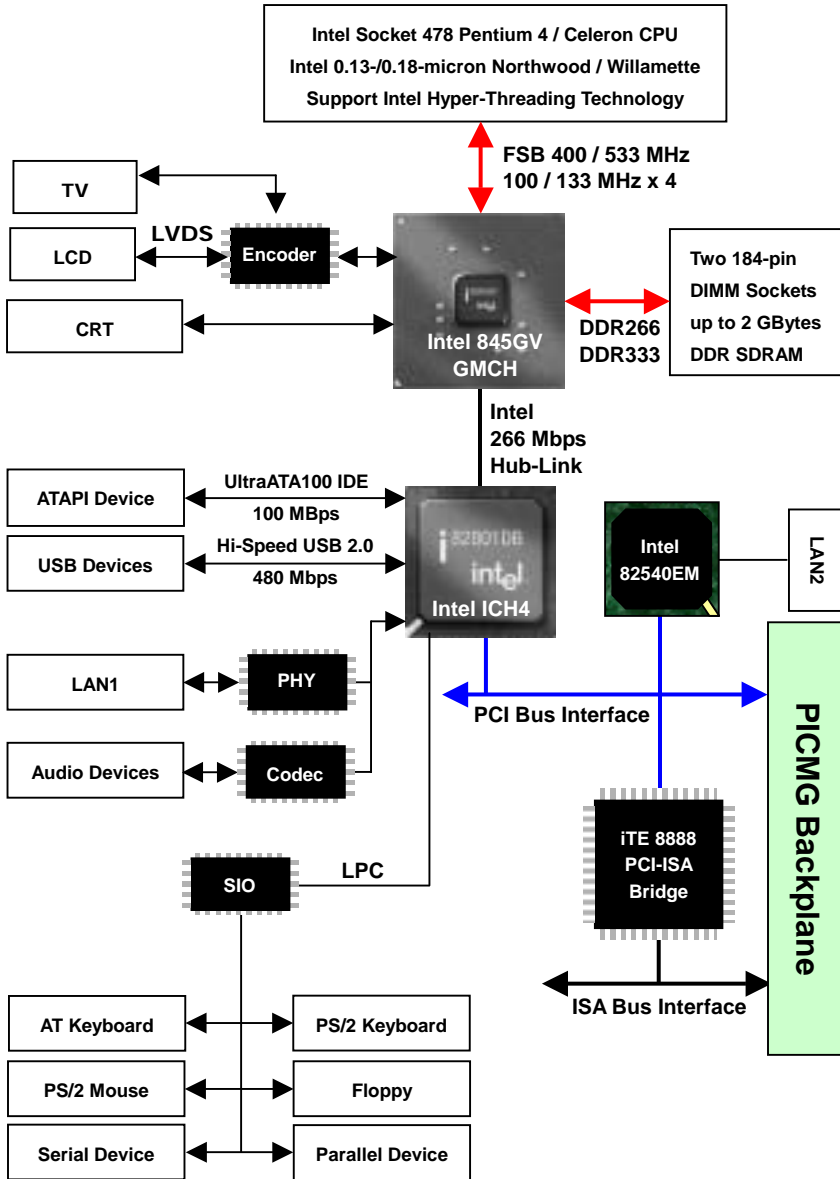



# Chapter 2. Hardware Setup

This chapter contains the information for installation of hardware. The install procedure includes jumper settings, CPU and memory installation, fan, I/O and panel connections.

## 2.1 Jumper and Connector Location

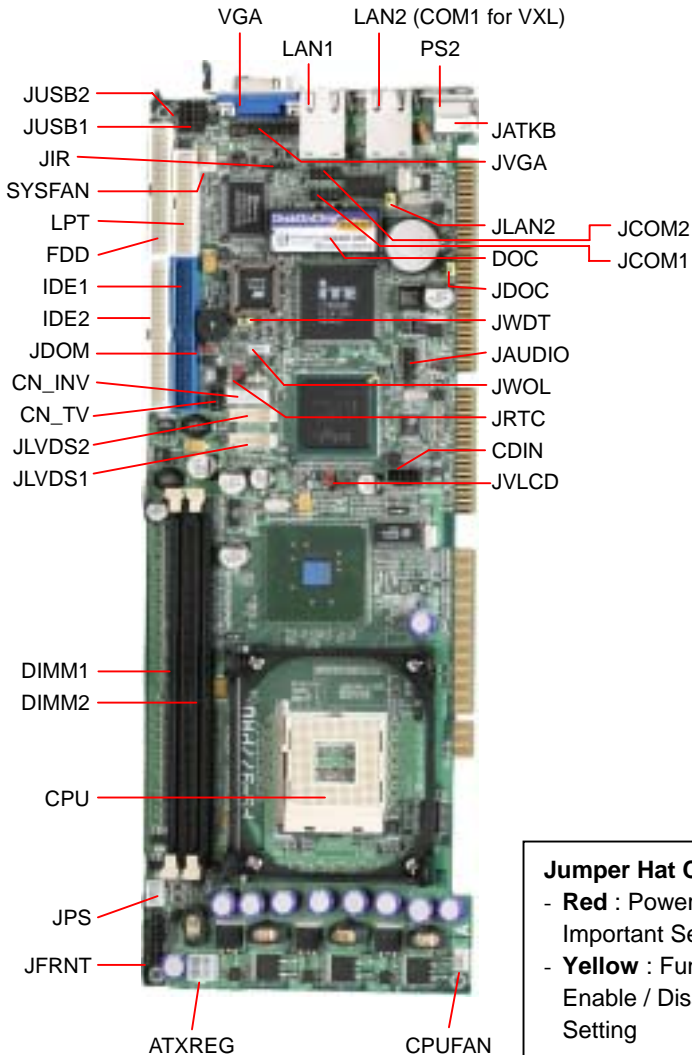

---

## 2.1.1 Jumper Reference

<b>Jumper</b>	<b>Function</b>	<b>Section</b>
JRTC	COMS Operate / Clear Setting	<a href="#">2.3</a>
JWDT	Watchdog Timer NMI / Reset Setting	<a href="#">2.4</a>
JDOC	DiskOnChip SSD Address Setting	<a href="#">2.5</a>
JDOM	DiskOnModule SSD Power Setting	<a href="#">2.5</a>
JVLCD	Flat Panel's Voltage Setting	<a href="#">2.7.2</a>
JLAN2	Secondary LAN Enable/Disable Setting	<a href="#">2.8</a>

---

## 2.1.2 Connector Reference

### Internal Onboard Connector

Connector	Function	Remark
CPU	MicroPGA478 CPU Socket	Standard
DIMM1/2	184-pin DIMM Socket	Standard
IDE1/2	40-pin Primary / Secondary IDE Port	Standard
FDD	34-pin Floppy Port	Standard
LPT	26-pin Parallel Port	Standard
JCOM1/2	10-pin COM1/2 Serial Port	Standard
USB1/2	10-pin 1st / 2nd (3rd / 4th) USB Port	Standard
JIR	5-pin SIR IrDA Port	Standard
DOC	32-pin DIP DiskOnChip Socket	Standard
JATKB	5-pin AT Keyboard Connector	Standard
ATXREG	4-pin Additional +12V Power Connector	Standard
JPS	3-pin ATX Signal Connector	Standard
JFRNT	14-pin Switch and Indicator Connector	Standard
CPUFAN	3-pin +12V CPU Fan Connector	Standard
SYSFAN	3-pin +12V System Fan Connector	Standard
JVGA	16-pin Internal VGA Port	Standard
JAUDIO	10-pin Audio Port	Standard
CDIN	4-pin CD-in Interface	Standard
WOL	3-pin Wake-On-LAN Interface	Standard
JLVDS1	20-pin LVDS interface	Standard
JLVDS2	20-pin LVDS interface	Standard
CN_INV	5-pin Backlight Inverter power connector	Standard
CN_TV	TV-out interface	Standard

### External Connector on Bracket

Connector	Function	Remark
VGA	DB15 Female VGA Connector	Standard
LAN1	RJ45 LAN1 Connector	Standard
LAN2	RJ45 LAN2 Connector	VXL2 only
COM1	DB9 Male COM1 Connector	VXL only
PS2	6-pin MiniDIN PS/2 Keyboard & Mouse	Standard

---

## 2.2 CPU and DRAM Setting

The board is based on Intel Socket 478 architecture with Intel 845GV chipset, supports Intel Socket 478 Pentium 4 / Celeron CPU at 533/400 MHz FSB.

System memory of this board supports up to 2 GBytes DDR200/266/333 SDRAM on two 184-pin DIMM sockets. Please notices that Intel 845GV GMCH **DOESN'T** support ECC and register DIMM.

## 2.3 CMOS Setting

The board's data of CMOS can be setting in BIOS. If the board refuses to boot due to inappropriate CMOS settings, here is how to proceed to clear (reset) the CMOS to its default values.

Jumper: **JRTC**

Type: onboard 3-pin header

JRTC	Mode
1-2	Clear CMOS
2-3	Normal Operation

Default setting

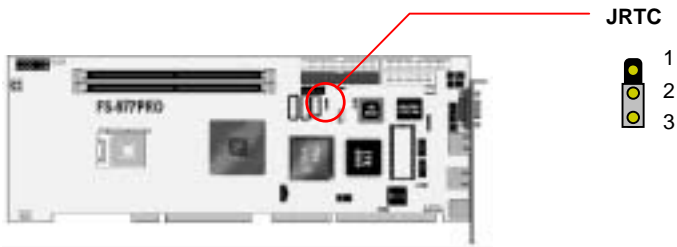

---

## 2.4 Watchdog Timer Setting

The watchdog timer makes the systems auto-reset while it stop to work for a period. The onboard watchdog timer can be setup as system reset or active NMI mode by jumper JWDT.

Jumper: **JWDT**

Type: onboard 3-pin header

JWDT	Watchdog Timer
1-2	Active NMI
2-3	Reset

Default setting

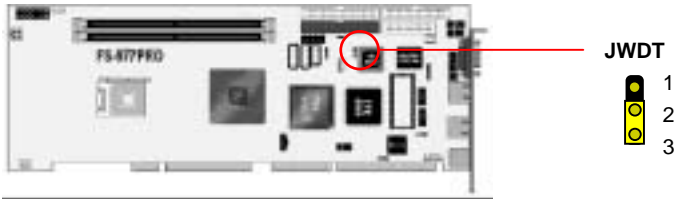

### Program Sample

Watchdog timer setup as system reset with 5 second of timeout

---

```
2E, 87
2E, 87
2E, 07
2F, 08      Logical Device 8
2E, 30      Activate
2F, 01
2E, F5      Set as Second*
2F, 00
2E, F6      Set as 5
2F, 05
```

---

\* Minute: bit 3 = 0; Second: bit 3 = 1

---

## 2.5 Embedded Solid State Disk

The board supports both 32-pin M-systems DiskOnChip 2000 and IDE-based DiskOnChip IDE Pro and DiskOnModule (DOM) embedded flash disk. The onboard 32-pin socket, DOC, supports DiskOnChip 2000 single chip flash disk in 32-pin DIP JEDEC with jumper selectable address on jumper JDOC; onboard 40-pin IDE2 box header supports normal DOM (DiskOnModule) or M-systems DiskOnChip IDE Pro flash disk with jumper selectable +5V Vcc power for cable free applications on jumper JDOM.

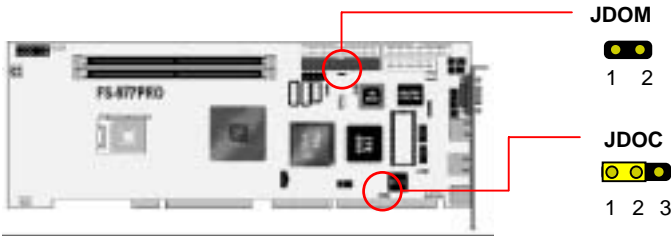

### DiskOnChip 2000 Address Setting

Jumper: **JDOC**

Type: onboard 3-pin header

JDOC	DiskOnChip Address
1-2	D000h
2-3	D800h

Default setting

### DOM or DiskOnChip 2000 IDE Pro Power Setting

Jumper: **JDOM**

Type: onboard 2-pin header

JDOM	+5V on Pin-20 of IDE2
OFF (Open)	Disable
ON (Close)	Enable

Default setting

## 2.6 Power and Fan Connector

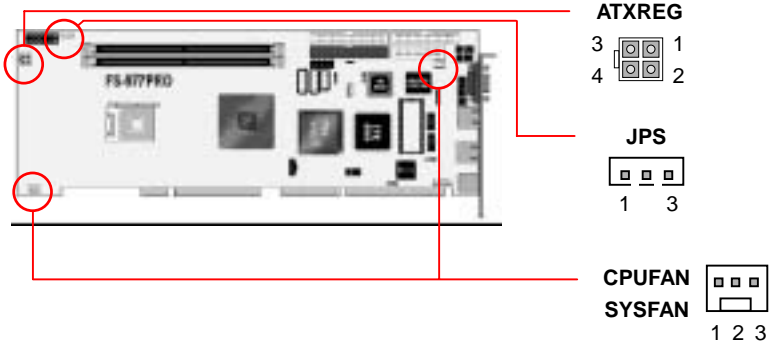

Connector: **ATXREG**

Type: 4-pin standard Pentium 4 additional +12V power connector

Pin	Description	Pin	Description
1	Ground	2	Ground
3	+12V	4	+12V

Connector: **JPS**

Type: 3-pin ATX wafer connector

Pin	Description	Pin	Description	Pin	Description
1	Power on	2	Ground	3	5V_Standby

Connector: **CPUFAN, SYSFAN**

Type: 3-pin fan wafer connector

Pin	Description	Pin	Description	Pin	Description
1	Ground	2	+12V	3	Fan Control

---

## 2.7 VGA Interface

### 2.7.1 Standard Analog VGA Interface

The board is integrated with Intel 845GV GMCH chipset built-in Intel Extreme Graphics with 266 MHz VGA core, 256-bit 3D engine and Intel Dynamic Video Memory up to 64 MBytes shared with system memory. The CRT / analog VGA interface includes one external DB15 female connector on bracket and one internal 16-pin header on board.

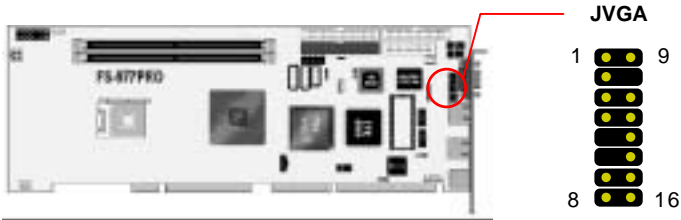

Connector: **JVGA**

Type: 16-pin (2 x 8) 2.54-pitch header

Pin	Description	Pin	Description
1	Red	9	Green
2	Blue	10	N/C
3	Ground	11	Ground
4	Ground	12	Ground
5	N/C	13	Ground
6	N/C	14	Data
7	HSYNC	15	VSYNC
8	Clock	16	N/C



---

## 2.7.2 Digital VGA Interface

The board provides an LVDS Interface, with Intel 845GV GMCH built-in Intel Extreme Graphics with CHRONTEL CH7017A-T encoder

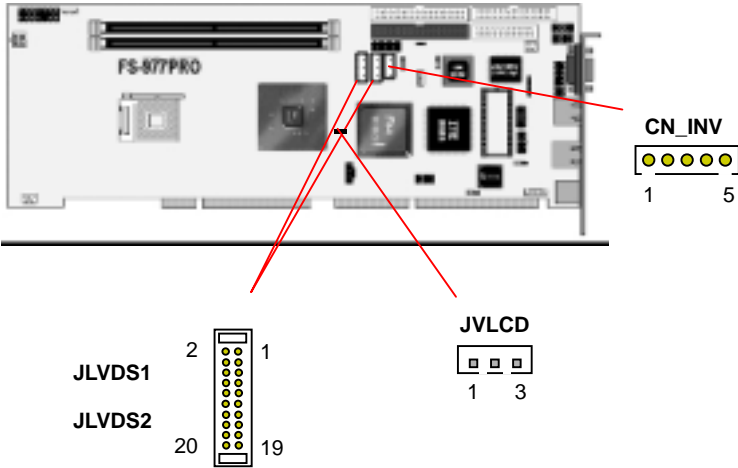

Jumper: **JVLCD**

Type: onboard 3-pin header

<b>JVOLT1</b>	<b>LCD Voltage Setting</b>
1-2	+5V
2-3	+3.3V
Default setting	

---

## LVDS TFT/DSTN LCD Interface

Connector: **JLVDS1**,

Type: onboard 20-pin Hirose DF13-20DP-1.25V

Pin	Signal	Pin	Signal
1	LCD_Vcc	2	LCD_Vcc
3	GND	4	GND
5	A0-	6	A0+
7	GND	8	A1-
9	A1+	10	GND
11	A2-	12	A2+
13	GND	14	CLK1-
15	CLK1+	16	GND
17	A3-	18	A3+
19	GND	20	GND

Connector: **JLVDS2**

Type: onboard 20-pin Hirose DF13-20DP-1.25V

Pin	Signal	Pin	Signal
1	LCD_Vcc	2	LCD_Vcc
3	GND	4	GND
5	A4-	6	A4+
7	GND	8	A5-
9	A5+	10	GND
11	A6-	12	A6+
13	GND	14	CLK2-
15	CLK2+	16	GND
17	A7-	18	A7+
19	GND	20	GND

## LCD Backlight Inverter Power Connector

Connector: **CN\_INV**

Type: 5-pin wafer connector

Pin	Description
1	+12V
2	Ground
3	Ground
4	Ground
5	ENABKL

---

### 2.7.3 TV-out Interface

The board provides the AV and S-video TV-out Interface at both of PAL and NTSC mode, with Intel 845GV chipset built-in VGA interface and CHRONTEL CH7017A-T encoder.

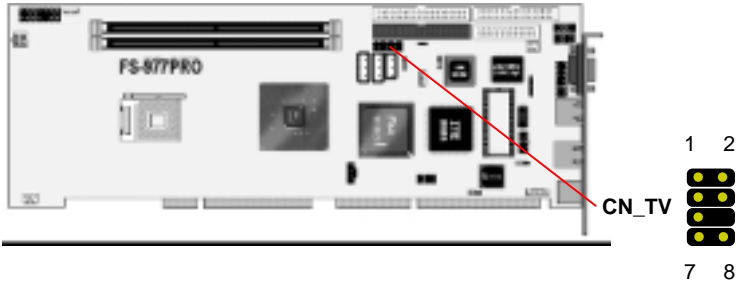

Connector: **CN\_TV**

Type: onboard 8-pin (2 x 4) 2.54-pitch pin header

Pin	Description	Pin	Description
1	Ground	2	TVY
3	TVC	4	Ground
5	Ground	6	N/C
7	TVCVBS	8	Ground

---

## 2.8 Ethernet Interface

The board integrated with one Intel PRO/100+ Fast Ethernet interface at the type of 10Base-T/100Base-TX auto-switching Fast Ethernet with full duplex and IEEE 802.3U compliant, and one Intel PRO/1000+ Fast Ethernet interface at the type of 10Base-T/100Base-TX/1000Base-T auto-switching Fast Ethernet with full duplex and IEEE 802.3, 802.3u, 802.3ab compliant. Both of them connect via RJ45 connectors on bracket. The LAN2 can enable or disable by jumper JLAN2.

The primary LAN interface is controlled by Intel ICH2 with Intel 82562ET and setting as LAN1. It provides the same performance as Intel 82559 LAN with the same driver. The secondary LAN interface is controlled by Intel 82540EM chipset and setting as LAN2.

Jumper: **JLAN2**

Type: onboard 3-pin (1 x 3) 2.54-pitch header

JLAN2	LAN2 Enable / Disable Setting
1-2	Enable
2-3	Disable

Default setting

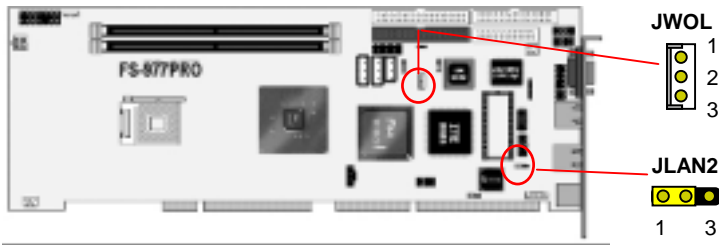

Connector: **JWOL**

Type: onboard 3-pin (1 x 3) wafer connector

Pin	1	2	3
Description	+5V Standby	Ground	WOL

---

## 2.9 Audio Interface

The board integrates with AC97 3D audio interface by Intel ICH4 and codec, provides line-in, line-out, Mic-in and CD-in interfaces for industrial applications with audio function.

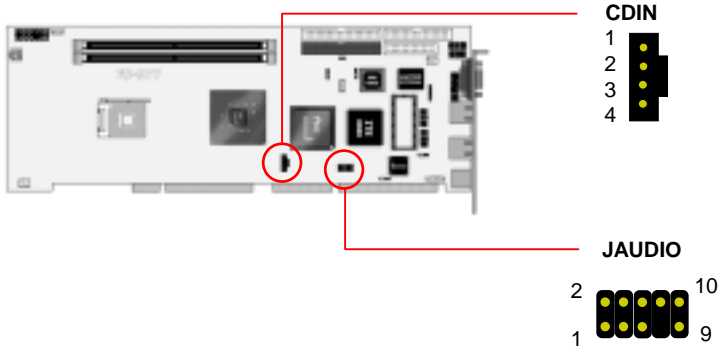

Connector: **JAUDIO**

Type: 10-pin (2 x 5) 2.54-pitch header

Pin	Description	Pin	Description
1	Line – Right	2	Ground
3	Line – Left	4	MIC
5	MIC	6	Ground
7	N/C	8	Line Out – Left
9	Line Out – Right	10	Ground

Connector: **CDIN**

Type: 4-pin header





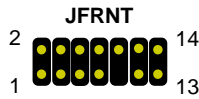

Pin	Description
1	CD – Left
2	Ground
3	Ground
4	CD – Right

## 2.10 Switch and Indicator



Connector: **JFRNT**

Type: onboard 14-pin (2 x 7) 2.54-pitch header

Function	Signal	PIN		Signal	Function	
<b>IDE LED</b>	Vcc (+)	1		2	(+) Vcc	<b>Power LED</b>
	Active	3		4	N/C	
<b>Reset</b>	Reset	5		6	GND	
	GND	7		8	Vcc	
N/C		9		10	N/C	<b>Speaker</b>
<b>Power</b>	PWRBT	11		12	N/C	
<b>Button</b>	GND	13		14	SPKIN	

---

## Chapter 3. BIOS Setup

The single board computer uses the Award BIOS for the system configuration. The Award BIOS in the single board computer is a customized version of the industrial standard BIOS for IBM PC AT-compatible computers. It supports Intel x86 and compatible CPU architecture based processors and computers. The BIOS provides critical low-level support for the system central processing, memory and I/O sub-systems.

The BIOS setup program of the single board computer let the customers modify the basic configuration setting. The settings are stored in a dedicated battery-backed memory, NVRAM, retains the information when the power is turned off. If the battery runs out of the power, then the settings of BIOS will come back to the default setting.

The BIOS section of the manual is subject to change without notice and is provided here for reference purpose only. The settings and configurations of the BIOS are current at the time of print, and therefore they may not be exactly the same as that displayed on your screen.

To activate CMOS Setup program, press < DEL > key immediately after you turn on the system. The following message “Press DEL to enter SETUP” should appear in the lower left hand corner of your screen. When you enter the CMOS Setup Utility, the Main Menu will be displayed as **Figure 3-1**. You can use arrow keys to select your function, press < Enter > key to accept the selection and enter the sub-menu.

**Figure 3-1.** CMOS Setup Utility Main Screen

Phoenix – Award BIOS CMOS Setup Utility

>Standard CMOS Features	>Frequency/Voltage Control
>Advanced BIOS Features	Load Fail-Safe Defaults
>Advanced Chipset Features	Load Optimized Defaults
>Integrated Peripherals	Set Supervisor Password
>Power Management Setup	Set User Password
>PnP / PCI Configurations	Save & Exit Setup
>PC Health Status	Exit Without Saving
Esc : Quit	↑ ↓ → ← : Select Item
F10 : Save & Exit Setup	

---

**Notes** (This page left blank intentionally)

A large, empty rectangular box with a thin black border, occupying most of the page. It is intended for the user to write notes, as indicated by the text above it.



---

## Chapter 4. Driver Installation

The driver CD offers auto-run menu. It will detect and select the type of single board computer and helps you install the drivers automatically.

### **Install Related Chipset INF Driver**

The selection helps you to install the INF of related chipset interface.

### **Install VGA Driver**

The selection helps you to install the driver of onboard VGA interface.

### **Install LAN Driver**

The selection helps you to install the driver of onboard LAN interface.

### **Install Audio Driver**

The selection helps you to install the driver of onboard audio interface.

### **Install Hi-Speed USB 2.0 Driver**

The selection helps you to install the driver of onboard USB 2.0 interface.

### **Link to < Website > Homepage**

The selection helps you to link to the website to find the updated technical documents and download directly.

### **Browse this CD**

The selection helps you to find the drivers in this CD directly.

---

**Notes** (This page left blank intentionally)

A large, empty rectangular box with a thin black border, occupying most of the page. It is intended for the user to write notes.

---

# Appendix. A I/O Port Pin Assignment

## A.1 IDE Port

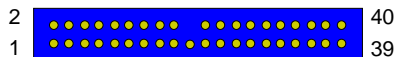

Connector: **IDE1, IDE2**

Type: 40-pin (2 x 20) 2.54-pitch box header

Pin	Description	Pin	Description
1	Reset	2	Ground
3	D7	4	D8
5	D6	6	D9
7	D5	8	D10
9	D4	10	D11
11	D3	12	D12
13	D2	14	D13
15	D1	16	D14
17	D0	18	D15
19	Ground	20	N/C (Vcc) *
21	REQ	22	Ground
23	IOW-/STOP	24	Ground
25	IOR-/HDMARDY	26	Ground
27	IRDY/DDMARDY	28	IDESEL
29	DACK-	30	Ground
31	IRQ	32	N/C
33	A1	34	CBLID
35	A0	36	A2
37	CS0 (MASTER CS)	38	CS1 (SLAVE CS)
39	LED ACT-	40	Ground

\* Jumper selectable Vcc power on IDE2 port for power cable free DOM (DiskOnModule).

## A.2 Floppy Port

Connector: **FDD**

Type: 34-pin (2 x 17) 2.54-pitch header

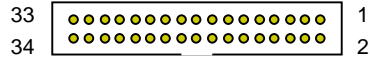

Pin	Description	Pin	Description
1	Ground	2	REDWC
3	Ground	4	N/C
5	Ground	6	N/C
7	Ground	8	INDEX-
9	Ground	10	MOTOR ENABLE A-
11	Ground	12	DRIVER SELECT B-
13	Ground	14	DRIVER SELECT A-
15	Ground	16	MOTOR ENABLE B-
17	Ground	18	DIRECTION-
19	Ground	20	STEP-
21	Ground	22	WRITE DATA-
23	Ground	24	WRITE GATE-
25	Ground	26	TRACK 0-
27	Ground	28	WRITE PROTECT-
29	Ground	30	READ DATA-
31	Ground	32	HEAD SELECT-
33	Ground	34	DISK CHANGE-

---

## A.3 Parallel Port

Connector: **LPT**

Type: 26-pin (2 x 13) 2.54-pitch box header

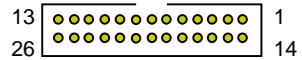

Pin	Description	Pin	Description
1	STROBE-	14	AUTO FEED-
2	D0	15	ERROR-
3	D1	16	INITIALIZE-
4	D2	17	SELECT INPUT-
5	D3	18	Ground
6	D4	19	Ground
7	D5	20	Ground
8	D6	21	Ground
9	D7	22	Ground
10	ACKNOWLEDGE-	23	Ground
11	BUSY	24	Ground
12	PAPER EMPTY	25	Ground
13	SELECT+	26	N/C

---

## A.4 Serial Port

### A.4.1 Onboard RS-232C Serial Port

Connector: **JCOM1, JCOM2**

Type: 10-pin (2 x 5) 2.54-pitch header



Pin	Description	Pin	Description
1	DCD	2	RXD
3	TXD	4	DTR
5	Ground	6	DSR
7	RTS	8	CTS
9	RI	10	N/C

### A.4.2 On Bracket RS-232C Serial Port

Connector: **COM1** (Optional for FS-977VL only)

Type: 9-pin D-sub male connector on bracket

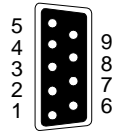

Pin	Description	Pin	Description
1	DCD	2	RXD
3	TXD	4	DTR
5	Ground	6	DSR
7	RTS	8	CTS
9	RI		

---

## A.5 USB Port

Connector: **USB1, USB2**

Type: 10-pin (2 x 5) header for dual USB Ports



Pin	Description	Pin	Description
1	Vcc	6	Vcc
2	Data0-	7	Data1-
3	Data0+	8	Data2+
4	Ground	9	Ground
5	Ground	10	N/C

## A.6 IrDA Port

Connector: **JIR**

Type: 5-pin (1 x 5) 2.54-pitch header for SIR Port



Pin	Description
1	Vcc
2	N/C
3	IRRX
4	Ground
5	IRTX

## A.7 VGA Port

Connector: **VGA**

Type: 15-pin D-sub female connector on bracket

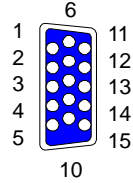

Pin	Description	Pin	Description	Pin	Description
1	RED	6	Ground	11	N/C
2	GREEN	7	Ground	12	VDDAT
3	BLUE	8	Ground	13	HSYNC
4	N/C	9	Vcc	14	VSYNC
5	Ground	10	Ground	15	VDCLK

## A.8 LAN Port

Connector: **LAN1, LAN2** (Optional for FS-977PROVXL2)

Type: RJ45 connector with LED on bracket

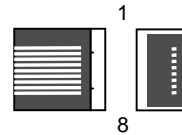

Pin	1	2	3	4	5	6	7	8
Description	TXD0+	TXD0-	RXI0+	RXI0-	GND	GND	N/C	N/C



---

## A.9 AT Keyboard Port

Connector: **JATKB**

Type: 5-pin box header

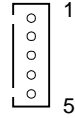

Pin	1	2	3	4	5
Description	Vcc	GND	N/C	DAT	CLK

## A.10 PS/2 Keyboard and Mouse Port

Connector: **PS2**

Type: 6-pin MiniDIN connector on bracket

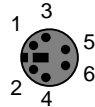

Pin	1	2	3	4	5	6
Description	KBD	MSD	Ground	N/C	KBC	MSC

Note: The PS/2 connector supports standard PS/2 keyboard directly or both PS/2 keyboard and mouse through the PS/2 Y-type cable. The cable is the standard on packing list.

---

**Notes** (This page left blank intentionally)

A large, empty rectangular box with a thin black border, occupying most of the page below the 'Notes' header. It is intended for the user to write notes.

---

# Appendix B. Flash the BIOS

## B.1 BIOS Auto Flash Tool

The board is based on Award BIOS and can be updated easily by the BIOS auto flash tool. You can download the tool online at the address below:

<http://www.award.com>

<http://www.wingtop.com.tw/Support/Support.htm>

File name of the tool is "awdfash.exe", it's the utility that can write the data into the BIOS flash ship and update the BIOS.

## B.2 Flash Method

1. Get the ".bin" file including the image of new BIOS you want to update.
2. Power on the system and flash the BIOS.
3. Re-star the system.

Any question about the BIOS re-flash please contact your distributors or visit our website at below:

<http://www.wingtop.com.tw/Support/Support.htm>

---

**Notes** (This page left blank intentionally)

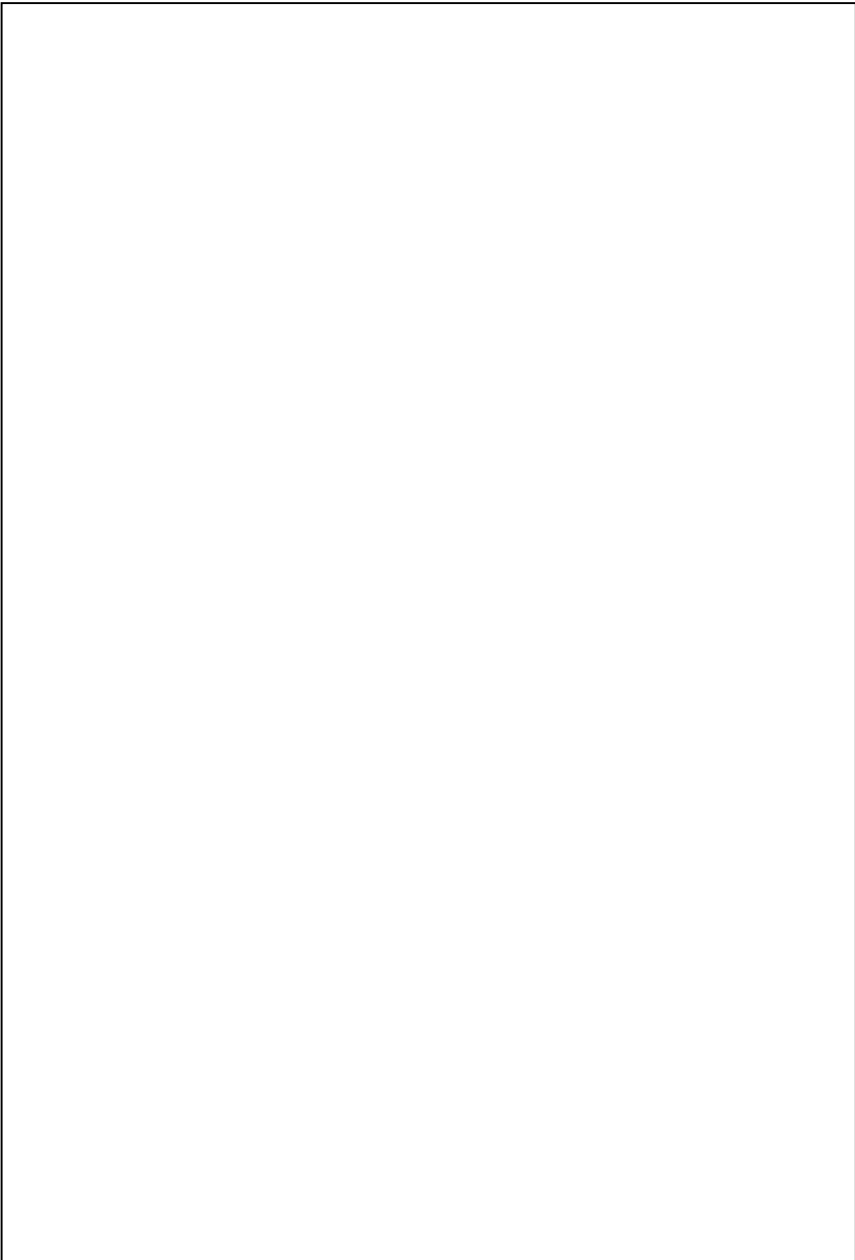
A large, empty rectangular box with a thin black border, occupying most of the page. It is intended for the user to write notes.

---

## Appendix C. System Resource

### C.1 I/O Port Address Map

<b>Address Range</b>	<b>Device</b>
0060-0060	i8042prt
0064-0064	i8042prt
0170-0177	atapi
01CE-01CF	VgaSave
01F0-01F7	atapi
02F8-02FE	Serial
0376-0376	atapi
0378-037A	Parport
0380-038B	VgaSave
03C0-03DF	VgaSave
03F0-03F5	Floppy
03F6-03F6	atapi
03F7-03F7	Floppy
03F8-03FE	Serial
C000-C03F	E100B
C400-C41D	E100E
E000-E0EF	alcxnt
E400-E43F	alcxnt

---

---

## C.2 Memory Address Map

<b>Device</b>	<b>Physical Address Length</b>
x00000000 - x0009FFFF	System board extension for PnP BIOS
x000A0000 - x000AFFFF	Intel(R) 82845G/GV Graphics Controller
x000B0000 - x000BFFFF	Intel(R) 82845G/GV Graphics Controller
x000C0000 - x000CADFF	Intel(R) 82845G/GV Graphics Controller
x000CAE00 - x000CBFFF	Motherboard resources
x000F0000 - x000F3FFF	Motherboard resources
x000F4000 - x000F7FFF	Motherboard resources
x000F8000 - x000FFFFFF	Motherboard resources
x00100000 - x00FFFFFF	System board extension for PnP BIOS
xE0000000 - xE7FFFFFFF	Intel(R) 82845G/GV Graphics Controller
xE8000000 - xEBFFFFFFF	Intel(R) 82845G/GV Processor to I/O Controller 2560
xEC000000 - xEC1FFFFFF	Intel(R) 82801DB PCI Bridge - 244E
xEC100000 - xEC11FFFF	Intel(R) GD82540EM PCI Adapter
xEC120000 - xEC120FFF	Intel(R) PRO/100 VE Network Connection
xEC121000 - xEC121FFF	Intel(R) GD82540EM PCI Adapter
xEC200000 - xEC27FFFF	Intel(R) 82845G/GV Graphics Controller
xEC280000 - xEC2803FF	Intel (R) USB Enhanced Host Controller (ICH4)
xEC281000 - xEC2811FF	Avance AC97 Audio
xEC282000 - xEC2820FF	Avance AC97 Audio
xFEC00000 - xFEC0FFFF	System board extension for PnP BIOS
xFEE00000 - xFEE0FFFF	System board extension for PnP BIOS
xFFB00000 - xFFB7FFFF	System board extension for PnP BIOS
xFFB80000 - xFFBFFFFFF	Intel(r) 82802 Firmware Hub Device
xFFFF0000 - xFFFFFFFFF	System board extension for PnP BIOS

---

---

## C.3 IRQ and DMA Resource

### C.3.1 IRQ

<b>IRQ Number</b>	<b>Device</b>
0	System timer
1	Standard 101/102-Key or Microsoft Natural Keyboard
2	Programmable interrupt controller
3	Communications Port (COM2)
4	Communications Port (COM1)
5	Intel(R) 82801DB/DBM USB Universal Host Controller - 24C2
5	IRQ Holder for PCI Steering
5	Intel(R) 82845G/GV Graphics Controller
6	Standard Floppy Disk Controller
7	Printer Port (LPT1)
8	System CMOS/real time clock
9	Intel (R) USB Enhanced Host Controller (ICH4)
9	IRQ Holder for PCI Steering
10	Avance AC97 Audio
10	Intel(R) 82801DB/DBM SMBus Controller - 24C3
10	Intel(R) GD82540EM PCI Adapter
10	Intel(R) 82801DB/DBM USB Universal Host Controller - 24C4
10	IRQ Holder for PCI Steering
11	Intel(R) PRO/100 VE Network Connection
11	Intel(R) 82801DB/DBM USB Universal Host Controller - 24C7
11	IRQ Holder for PCI Steering
12	PS/2 Compatible Mouse Port
13	Numeric data processor
14	Primary IDE controller (dual fifo)
14	Intel(R) 82801DB Ultra ATA Storage Controller - 24CB
15	Secondary IDE controller (dual fifo)
15	Intel(R) 82801DB Ultra ATA Storage Controller - 24CB

---

### C.3.2 DMA

<b>Channel</b>	<b>Device</b>
0	(free)
1	(free)
2	Standard Floppy Disk Controller
3	(free)
4	Direct Memory Access Controller
5	(free)
6	(free)
7	(free)

---



---

## Contact Information

Any advice or comment about our products and service, or anything we can help you please don't hesitate to contact with us. We will do our best to support you for your products, projects and business.

**WINGTOP Industrial Computer**  
**Taiwan WINGTOP Co., LTD.**

**WINGTOP**

[www.wingtop.com.tw](http://www.wingtop.com.tw)

Your Industrial Computer Partner

---

Address	No.9, Kong 6 <sup>th</sup> Road., 2 <sup>nd</sup> Industry Park, Lin Kou, Taipei Hsien, Taiwan
TEL	+886-2-26018686
FAX	+886-2-26013586
Website	<a href="http://www.wingtop.com.tw">http://www.wingtop.com.tw</a>
E-mail	<a href="mailto:sales@wingtop.com.tw">sales@wingtop.com.tw</a> (General Information) <a href="mailto:support@wingtop.com.tw">support@wingtop.com.tw</a> (Technical Support)

---

### Authorized Distributor